



**300W SECONDARY CONTROLLED TWO-SWITCH FORWARD CONVERTER WITH L4990A**

by: N.Tricomi C. Adragna

**INTRODUCTION**

A typical off-line isolated switch-mode power supply has the controller located on the primary side of the transformer, whereas the output voltages to be controlled and the housekeeping functions are located on the secondary side. Usually the voltage feedback signal is transferred to the primary controller by using an optocoupler or a transformer.

We want to propose here an asymmetrical half bridge forward converter with the controller located on the secondary side. This solution offers some advantages:

- direct use of the on-board voltage reference
- no need of the opto feedback, with its temperature and ageing gain dependence
- available on-board housekeeping functions eliminates the need of an additional dedicated device
- negligible extra cost on the gate drive transformer to satisfy safety requirements

The controller operating on the secondary side requires a specific concept for the start-up sequence, realised here with a very simple, low consumption and cost effective solution.

**POWER SUPPLY DESCRIPTION**

**Topology**

Considering the 300W of output power delivered to the load, the most appropriate topology is the asymmetrical half bridge converter.

This topology requires two power MOS transistors with a voltage breakdown equal or little higher than the max. rectified mains voltage (thanks to the two clamping diodes), with a proper  $R_{dson}$  to reach the target efficiency.

Fig. 1 shows the complete schematic diagram of the 300W Power Supply.

**Start-up circuit**

As already mentioned in the introduction section, the controller is located on the secondary side of the power transformer, and for this reason, a start-up circuit has to be provided for a correct system activation.

The start-up circuit is based on a diac sending a train of controlled pulses to the low side drive section; the floating drive section is energised by the second secondary gate drive transformer winding.

As soon as the L4990 wakes-up, it generates a pwm signal enabling the start-up circuit.

**Gate driver**

The two power mosfets, T1 and T2, are driven by a small transformer designed to satisfy the isolation safety requirements and fast switching times.

For optimum magnetic coupling (required by the high switching frequency operation) and minimum number of turns, a high permeability core has been selected.

**POWER SUPPLY SPECIFICATION**

Symbol	Description	Parameter
$V_I$	Input voltage	220Vac (176 Vac to 265 Vac) // 50Hz
$V_O$	Output voltage	24V % (ripple voltage <1%)
$I_O$	Output Current	13A max. continuous, 0.5A min
$I_l$	Limiting Current	constant type till ground
$P_o$	Output continuous power	312W
$f_s$	Switching Frequency	200kHz
$\eta$	Target Efficiency (full load)	= 90% (from mains to output)

# AN890 APPLICATION NOTE

Figure 1: Schematic Diagram of 300W power supply

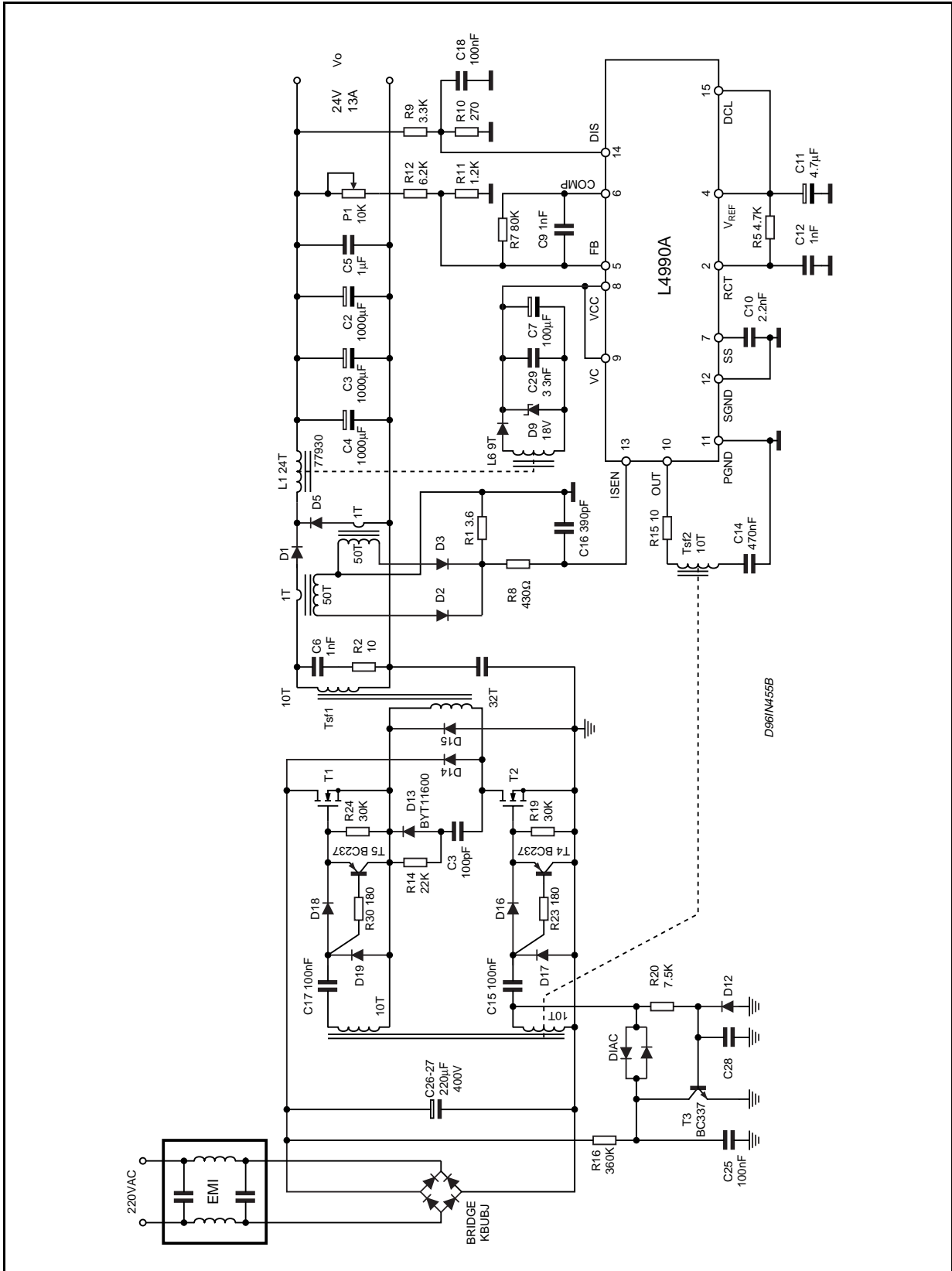

The core is E20/10/5-3C85, 10 turns/winding, no air-gap.

A high permeability core minimises the magnetising current to maintain a correct operation far away of the core saturation point, at maximum duty cycle and high core temperature.

The proposed gate drive circuit allows the use of the 1:1:1 turns ratio drive transformer; moreover, a controlled drain current rise time (by R15) and a fast fall time are achieved.

A very short min. Ton pulse give the possibility to stabilise the output voltage at max. mains and min. load.

**Power MOS selection**

The two-switch topology allows to use the power elements with a voltage breakdown equal to the max. rectified mains voltage.

The mosfet used here is the STW15NB50; this device, with 500V of BVdss give us also some safety margin.

The basic parameters of the STW15NB50 are listed below:

Rdson (25°C) = 0.36Ω max., at Id = 7.5A (0.72Ω max. at 100°C)

Coss = 430pF max., Qg = 80nC max., package in TO-247

At min. supply voltage and max. load current, the conduction losses for each transistor are:

$P_{con} = I_{rmsp}^2 \cdot R_{dson}(100^\circ C) = 2.23^2 \cdot 0.72 = 3.6W$  where the effective  $I_{rmsp}^2$  is calculated in the power transformer section.

Estimating in about 3.5W switching and parasitic losses, the total power losses of each transistor are about 7W.

Considering 100°C of maximum operating junction temperature (at 40°C of ambient temperature) and a thermal resistance junction-heatsink of 0.76°C/W, a heatsink of 3.5 °C/W is required to dissipate both the transistors.

**Current sense**

Considering the output current rating of 13A continuous, it's our opinion that a current transformer for current sensing is the best approach for maximising the efficiency, reliability and internal ambient temperature in case the power supply has to be housed in a plastic box.

Due to the constant current limiting requirements, as shown in Fig2, a couple of current transformers have been used; one transformer is sensing the current flowing into D1 (in conduction when T1 and T2 are ON) and the second one is sensing the current flowing into D5, recirculation diode.

Oring the two transformers by D2 and D3, and closing the loop with a proper impedance value,



R1, we realise a voltage signal reproducing exactly the inductor current shape.

The current sensing loop is closed by R1 selected according the transformers turns.

Two small toroid ferrite cores (41005-TC, Magnetics, F material, 3000μ) have been used, with 50 turns.

R1 is defined by:

$$R1 = \frac{50 \cdot 1V}{I_{pk}}$$

where:

1V is the nominal threshold voltage of the current sense.

Ipk is the inductor peak current( considering a 20% of current ripple,  $I_{pk} = I_o + \Delta I/2 = 13 + 1.3 = 14.3A$ )

**Figure 2:** Output limiting current characteristic using two current transformers

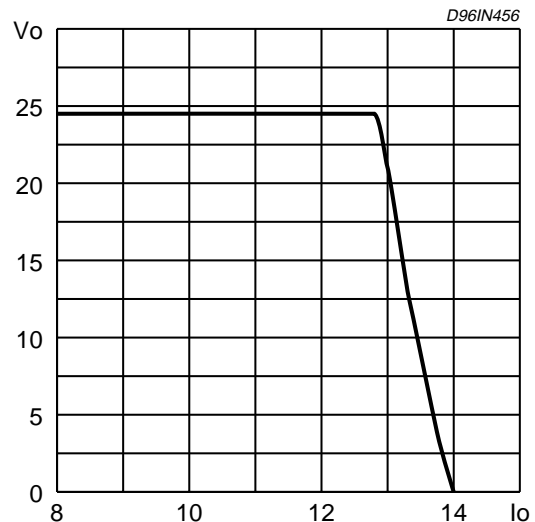

The calculated value is  $R1=3.5\Omega$

Fig. 2 shows the constant current characteristic using two current transformers.

The difference from the two current values, at output short-circuit and at current limiting intervention, is proportional to the half of chocke ripple current.

A choke with higher value or higher switching frequency, can reduce this difference.

If constant current feature is not requested to be constant till the output is reaching zero V, one single current transformer can be used.

The new limiting current characteristic and the schematic diagram are shown in Fig 3a and 3b:

In order to reduce the peak current before hiccup intervention, an offset can be superimposed to the current sensing circuit to anticipate the hiccup limiting current intervention, by using the addi-

**Figure 3a:** Output limiting current characteristic using one current transformers.

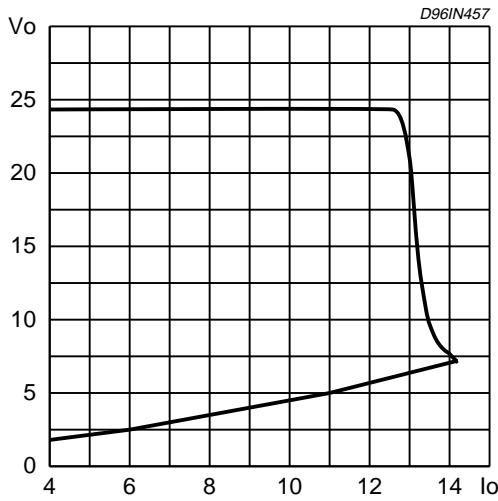

**Figure 3b:** limiting current schematic diagram

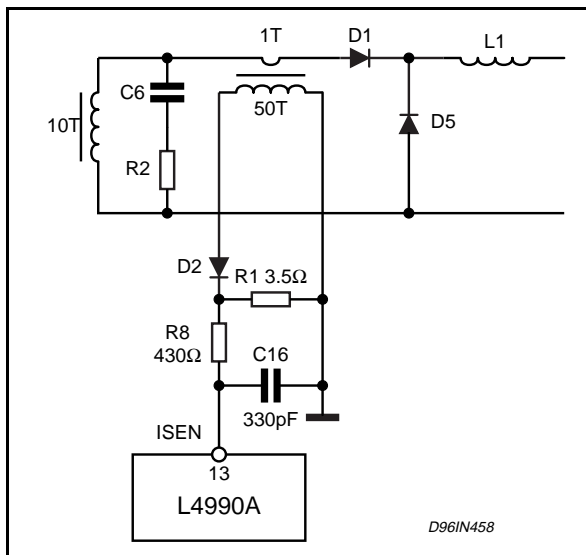

tional network shown below ( figs. 4a and 4b):  
Using this solution, also the  $\Delta I/\Delta V_o$  is higher, reducing the difference from the intervention point and the short circuit current values.  
This solution can be used with two current transformers too.

**Output Diode selection**

The reverse voltage of the output diodes is given by the formula:

$$V_r = V_{in\ max}/n = 375/3,3 = 114V,$$

**Figure 4a:** Schematic diagram of the modified hiccup limiting current threshold

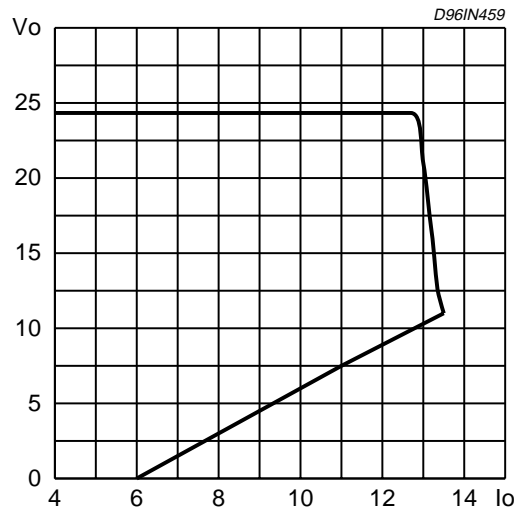

**Figure 4b:** Output limiting current characteristic

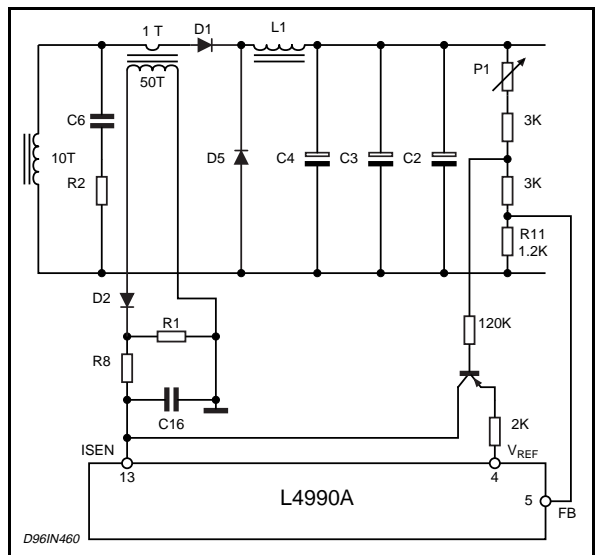

where n is the transformer turns ratio.

For a correct functionality a ultra-fast recovery diode is requested, mainly to limit switching losses and EMI problems.

To calculate the conduction losses the following equation has been applied to the selected type, BYV52-200.

For the single diode the formula is:

$$P = 0.7 \cdot I_{(AV)} + 0.0075 \cdot I_{(RMS)}^2$$

that, rearranged to take into account both the diodes, becomes:

$$P = 0.7 \cdot I_{O\text{MAX}} + 0.0075 \cdot I_{O\text{MAX}}^2 = 10.4\text{W}$$

where  $I_{O\text{MAX}} = 13\text{A}$ .

Considering the TO247 package (1.2 °C/W total thermal resistance junction-heatsink), to ensure that the junction temperature does not exceed 100 °C at 40 °C max. ambient temperature, the heatsink has to be dimensioned for about 4°C/W.

**Power transformer design**

The forward transformer delivers energy from the primary to the secondary without any storage.

The only consideration is with regards of the magnetising current, that has to be limited at a safety value far from core saturation.

Our core selection is based on AP, area product, defined as  $AP = Aw \cdot Ae$ .

The minimum AP to avoid saturation is:

$$AP = \left( \frac{67.2 \cdot P_o}{\eta \cdot \Delta B \cdot f} \right)^{1.31} \text{ cm}^4$$

The AP necessary to limit the core temperature rise not above 30 °C is

$$AP = \left( \frac{235 \cdot P_o}{\eta \cdot f} \right)^{1.58} (Kh \cdot f + Ke \cdot f^2)^{0.66} \text{ cm}^4$$

Where:

$P_o$  = output power

$\Delta B$  = flux swing

$f$  = switching frequency

$\eta$  = efficiency

$Ke = 4 \cdot 10^{-10}$

$Kh = 4 \cdot 10^{-5}$

In this application ( $P_o = 312\text{W}$ ,  $\eta = 90\%$ ,  $f = 200\text{KHz}$ ) and considering a maximum  $\Delta B=200\text{mT}$  for saturation, the most stringent condition is determined by the formula related to the core temperature raise.

The minimum AP required is  $1.97 \text{ cm}^4$ . The selected core is ETD39 ( $AP = 2.2 \text{ cm}^4$ ) in 3F3 material.

Assuming total losses of 1% of  $P_o$  (3W), 2/3 (2W) for the core and 1/3 (1W) for the copper, the specific core losses are:

$$P = \frac{P_{fe}}{V_e} = \frac{2\text{W}}{11.5\text{cm}^3} = 0.173\text{W/cm}^3$$

In presence of such a power losses, the flux

swing can be determined, for 3F3 material, by using the diagram of material, at 200KHz :

**Figure 5:** Specific power loss as a function of frequency peak flux density with frequency as a parameter

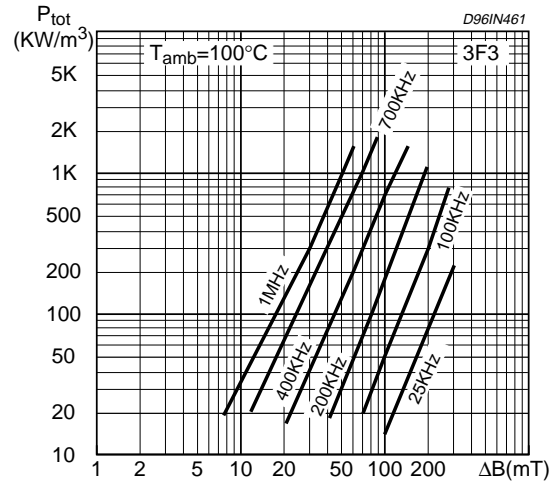

or by using the empirical formula

$$\Delta B = \left( \frac{P}{Kh \cdot f + Ke \cdot f^2} \right)^{0.416} = \frac{0.173}{4 \cdot 10^{-5} \cdot 200 \cdot 10^3 + 4 \cdot 10^{-10} \cdot (200 \cdot 10^3)^2} = 130\text{mT}$$

With a specific core losses of 173 mW/cm<sup>3</sup> the flux swing must not exceed 130mT

The minimum primary turns is given by:

$$N_p \geq \frac{V_{in\text{mindc}} \cdot T_{on(\text{max})}}{\Delta B \cdot A_e} \cdot 10^4 = \frac{200 \cdot 2.4}{0.130 \cdot 125} = 29.5$$

where  $T_{on}$  is in sec,  $\Delta B$  in Tesla and  $A_e$  in  $\text{mm}^2$ .

The turns ratio is defined as:

$$n = 0.9 \cdot \frac{V_{in(\text{min})} \cdot D_{\text{max}}}{V_o + V_f + V_p} = 0.9 \cdot \frac{200 \cdot 0.48}{24 + 1 + 0.5} = 3.38$$

where:

$D_{\text{max}} = 0.48$  (maximum duty cycle):

$V_f = 1\text{V}$  (voltage drop of the output diode);

$V_p = 0.5\text{V}$  (voltage drop of the output inductor).

The primary and secondary turns number are

$N_p = 32$ ,  $N_s = 10$ .



## AN890 APPLICATION NOTE

As for the wire selection, the skin effect is not negligible at this frequency.

To reduce this effect, the wire diameter should not exceed two times the penetration depth:

$$\delta = \frac{7.5}{\sqrt{f}} = 0.17\text{mm}$$

and therefore a wire diameter of 0.36mm (AWG27) is suitable. However, to have a sufficient copper area, a certain number of these wires will be twisted together.

To define the numbers of wires this equation can be used:

$$N_{\text{wire}} = R \cdot N_{\text{turns}} \cdot l_w \cdot \frac{I_{\text{rms}}^2}{P_{\text{loss}}}$$

where:

R = resistance of the wire per cm

l<sub>w</sub> = winding length (cm)

As to the primary side:

$$I_{\text{rmsp}} = \frac{P_o}{\eta \cdot V_{\text{inmindc}} \cdot \sqrt{D_{\text{max}}}} = \frac{312}{0.9 \cdot 200 \cdot \sqrt{0.48}} = 2.23\text{A}$$

The RMS secondary current is 3.4 times the primary one. Considering the copper losses equally dissipated between primary and secondary windings, this yields 3 wires in parallel (N<sub>pwire</sub>) for the primary winding and 10 wires (N<sub>swire</sub>) for secondary winding.

The ETD39 core has a winding area of 1.7 cm<sup>2</sup> but the real available space is approximately 40% (0.68 cm<sup>2</sup>): isolation requirements and fill factor must be taken into account. The total copper area is:

$$A_{\text{tot}} = A_{\text{is}} \cdot (N_{\text{pwire}} \cdot N_p + N_{\text{swire}} \cdot N_s) = 0.255 \text{ cm}^2$$

that fits the window.

The windings are interleaved:

one layer of 16 turns (first half of the primary), one layer of 10 turns (the secondary) and another layer of 16 turns (second half of the primary).

With this arrangement the transformer used in the application has a leakage inductance of 15μH (about 0.5% of the primary inductance, which is 2.7 mH).

The magnetising current is:

$$I_m = \frac{V_{\text{in(min)}} \cdot t_{\text{on}}}{L_p} = \frac{200 \cdot 2.4 \cdot 10^{-6}}{2.7 \cdot 10^{-3}} = 180\text{mA}$$

The primary peak current is:

$$I_{\text{pk}} = \frac{P_o}{\eta \cdot V_{\text{inmindc}} \cdot D_{\text{max}}} = \frac{312}{0.9 \cdot 200 \cdot 0.48} = 3.22\text{A}$$

A good condition is when I<sub>m</sub> 10% of I<sub>pk</sub>; in this case I<sub>m</sub> is imposed lower than 6% of I<sub>p</sub>.

### Output inductor & auxiliary supply

To calculate the inductor value, the max. current ripple has been set at 2.6A, 20% of I<sub>omax</sub>.

The max. current ripple occurs at max. input voltage; in this operating condition the min duty cycle is:

$$D_{\text{min}} = \frac{n \cdot (V_o + V_{\text{loss}})}{V_{\text{inmax}}} = \frac{3.2 \cdot (24 + 1.5)}{375} = 0.22$$

The inductor value is defined taking into account the current downslope which corresponds to the off-time of the power switches:

$$T_{\text{off max.}} = T \cdot (1 - D_{\text{min}}) = 5 \cdot (1 - 0.22) = 3.9\mu\text{s}$$

that yields:

$$L_o = \frac{(V_o + V_{\text{loss}}) \cdot T_{\text{offmax}}}{\Delta I_{\text{max}}} = \frac{(24 + 1.5) \cdot 3.9 \cdot 10^{-6}}{2.6} = 39\mu\text{H}$$

To realise the inductor, a Magnetic's Kool M<sub>μ</sub> Core 77930 has been used. Since the inductor has to assure the requested value at maximum load current, the turns number must be calculated taking into account the roll-off of the initial permeability. This results in 24 turns, that leads to 90 μH at zero load.

We can take advantage of this non-linear characteristic to keep a good output regulation and stability when working at min. load current( around 0.5A for this case).

From the output inductor it is drawn also the energy necessary to supply the L4990 controller by

introducing a 9 turns auxiliary winding.

**Input capacitor**

The input filtering capacitor has to be dimensioned in order to deliver the requested max. output power, at min. mains value, with a reasonable ripple voltage at 100Hz.

The design process has to consider also the rms current flowing into the capacitor ( a major reason of stress) and the voltage rating.

The minimum capacitor value is defined by:

$$C = \frac{P_o}{\eta \cdot F_{50} \cdot (V_{cp}^2 - V_{cm}^2)} = \frac{312}{0.9 \cdot 50 \cdot (248^2 - 200^2)} = 310\mu F$$

where:

Vcp is the peak value at minimum mains voltage, 248V

Vcm is the minimum value at minimum mains voltage, 200V

The chosen capacitors are 2 x 220µF - 400V EYS 06.

At this point the new Vcm value is 215V.

The conduction time is:

$$t_c = \frac{\cos^{-1}\left(\frac{V_{cm}}{V_{cp}}\right)}{2 \cdot \pi \cdot F_{50}} = \frac{\cos^{-1}\left(\frac{215}{248}\right)}{2 \cdot 3.14 \cdot 50} = 1.68 \cdot 10^{-3} \text{sec}$$

The input capacitor peak current is:

$$I_{ch} = \frac{C \cdot (V_{cp} - V_{cm})}{t_c} = \frac{440 \cdot 10^{-6} \cdot (248 - 215)}{1.6 \cdot 10^{-3}} = 8.8A$$

The RMS current that the capacitor has to sustain is:

$$I_{rms} = I_{ch} \cdot \sqrt{2 \cdot t_c \cdot F_{50} - (2 \cdot t_c \cdot F_{50})^2} = 8.8 \cdot \sqrt{3.2 \cdot 10^{-3} \cdot 50 - (3.2 \cdot 10^{-3} \cdot 50)^2} = 3.32A$$

$$I_{rmstot} = \sqrt{I_{rms50}^2 + \frac{I_{rms200KHz}^2}{1.6}} =$$

$$= \sqrt{3.32^2 + 2.23^2} = 3.76A$$

Considering the sensitivity to the temperature of the electrolytic capacitors, and the difficulties in fixing exactly the effective rms current value, for this particular part number, with an ambient temperature of 40°C, the permitted temperature case is 85 °C.

The selected capacitors show a 1.4Arms each of current capability at Tcase 85°C; that's enough to sustain our operating conditions.

**Output capacitors**

The output capacitor value is selected on the basis of the output voltage ripple requirement. This ripple is basically due to the ESR, since the capacitive component is by far lower. Then it must be ensured that the total ESR is below a maximum value of:

$$ESR_{max} = \frac{\Delta V_{ripple}}{\Delta I_{max}} = \frac{0.24V}{2.6A} = 0.092\Omega$$

where the ripple voltage has been fixed at 1% max. of Vo.

Three capacitors EKE 1000µF/35V (ROE) have been paralleled, for a total ESR of about 23mOhm.

**Compensation network**

The power supply system can be simplified in two parts: Power and Feedback loop blocks.

The transfer function of the Power block is:

**Figure 6:** Closed loop block diagram

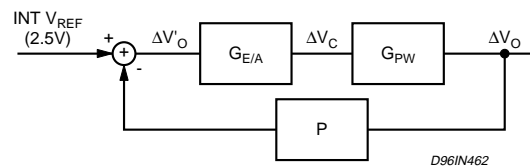

$$G_{pw}(s) = \frac{\Delta V_o}{\Delta V_c} = \frac{n}{3 \cdot R_s} \cdot R_o \cdot \frac{1 + \frac{s}{S_z}}{1 + \frac{s}{S_p}}$$

## AN890 APPLICATION NOTE

where:

- $\Delta V_o$  is the small signal output voltage
- $\Delta V_c$  is the small signal error amplifier output voltage
- $S_p$  is determined by the load ( $R_o$ ) and the output capacitance
- $S_o$  is determined by the ESR and the value of the output capacitance
- $n$  is the current transformer turn number
- $R_s$  is the sense resistance

A load regulation of 1.5% has been imposed that corresponding to a maximum output voltage variation of 360mV. The power block DC gain is:

$$G_{pw} = \frac{\Delta V_o}{\Delta V_c} = \frac{n \cdot R_o}{3 \cdot R_s}$$

Considering a load variation between  $I_o=0.1A$  and  $I_o=13A$ , that corresponds to  $R_o=240\Omega$  and  $R_o=1.84 \Omega$ , the  $\Delta V_c$  excursion is:

$$\Delta V_c = \frac{V_o \cdot 3 \cdot R_s}{n} \cdot \left( \frac{1}{R_{omin}} - \frac{1}{R_{omax}} \right) = 2.7V$$

The E/A DC gain and the voltage divisor must be selected to fit this condition

$$\frac{\Delta V_o}{\Delta V_c} = 7.5$$

The output voltage divider usually sinks a current of about 2mA and the resistance values are:

$$R11 = 12k\Omega$$

$$P1 + R12 = 1k\Omega$$

The  $R7$  value is:

$$R7 = \frac{\Delta V_o}{\Delta V_c} \cdot (P1 + R12) = 80k\Omega$$

It is necessary to introduce a pole at about one third of the zero frequency and  $C9$  is:

$$C9 = \frac{1}{2 \cdot \pi \cdot F_z \cdot 3 \cdot R7} = 1.8nF$$

### Overvoltage protection

The voltage divider,  $R9$  and  $R10$ , is providing for

fixing the threshold for overvoltage protection intervention. With the selected values, the threshold is fixed at 30V.

$C18$  is fixing the min. overvoltage time intervention to avoid OVP triggering from spikes.

For an OVP function in tracking with the output voltage, in particular when  $V_o$  is adjustable, it's enough to substitute the  $R11$  resistor with a voltage divider, and to connect the common point to pin14.

### Evaluation results

Fig 7 show the efficiency values obtained in different working conditions of input voltages and output currents.

The efficiency is from ac mains to output dc voltage, at a measured switching frequency of 200kHz.

**Figure 7:** Efficiency versus output load current and min., typ. and max. ac voltage.

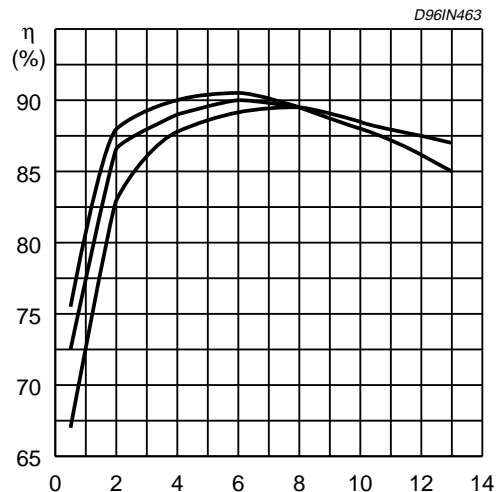

**Figure 8a:** Output voltage response versus Fig 8b. Enlarged section of load

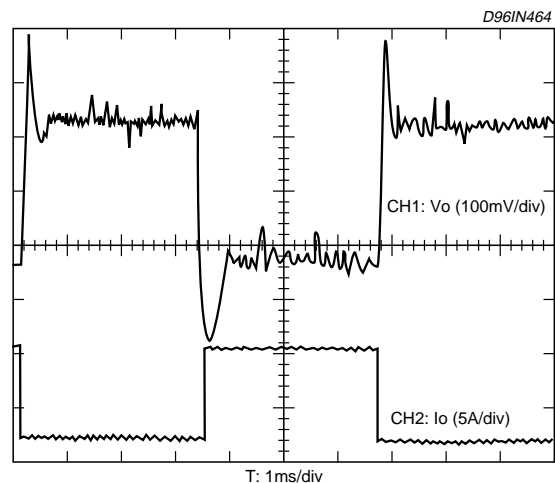

The efficiency is quite constant and equal or above 85% from 2A to full load.

At min. load of 0.5A, it's 70% at 220Vac. The total losses, for an amount of 3.6W are mainly due to Coss of the power mos devices and transformer core losses due to the magnetizing current.

**Figure 8b:** Englarged section of load transient response at load current rise

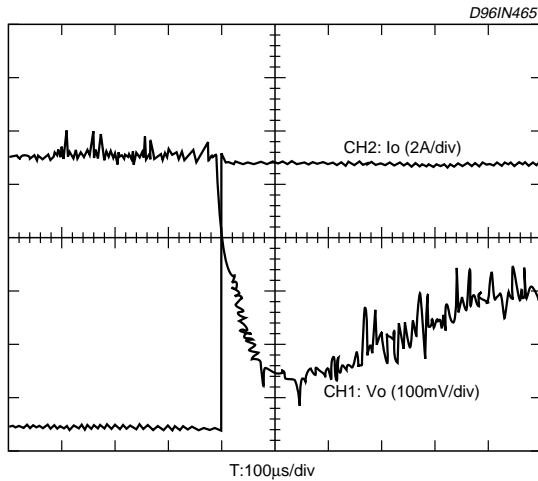
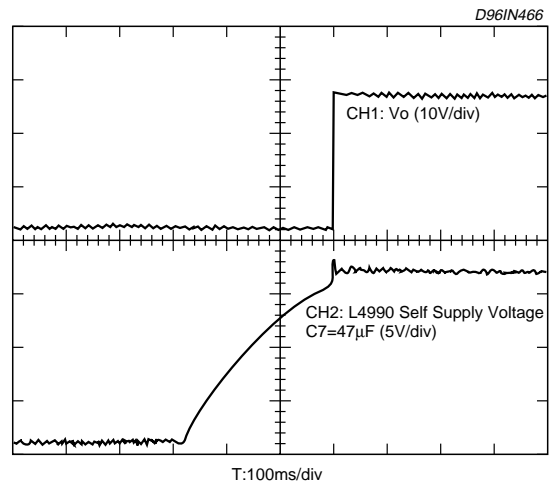

Fig 8a. shows the load transient response, at nominal ac input voltage value and output load variation from 1A to 12A, in a couple of msec, and fig 8b shows the enlarged section at the moment of current load rise.

Fig 9. To be noticed the absence of output overshoot on the output voltage.

**Figure 9:** show the turn-on time at mains switch-on



Information furnished is believed to be accurate and reliable. However, STMicroelectronics assumes no responsibility for the consequences of use of such information nor for any infringement of patents or other rights of third parties which may result from its use. No license is granted by implication or otherwise under any patent or patent rights of STMicroelectronics. Specification mentioned in this publication are subject to change without notice. This publication supersedes and replaces all information previously supplied. STMicroelectronics products are not authorized for use as critical components in life support devices or systems without express written approval of STMicroelectronics.

The ST logo is a registered trademark of STMicroelectronics

© 1999 STMicroelectronics – Printed in Italy – All Rights Reserved

STMicroelectronics GROUP OF COMPANIES

Australia - Brazil - China - Finland - France - Germany - Hong Kong - India - Italy - Japan - Malaysia - Malta - Morocco -  
Singapore - Spain - Sweden - Switzerland - United Kingdom - U.S.A.

<http://www.st.com>